

序号	物料编码	零件图号	英文名称	物料名称	用量
NO.	PART CODE	drawing ref.code	Description	Description	Quantity
1	1. 29. 04. 0400000	PD350E-0404-000	Bearing 30205	轴承30205	1
2	1. 66. 11. 0000100	DD250G-1100-001	Fuel tank cushion	油箱缓冲垫	2
3	1. 99. 52. 1000000	GB97. 1-85	Flat washer 10 (Φ10.5 × Φ20 × 2)	平垫圈10 (Φ10.5 × Φ20 × 2)	2
4	1. 01. 02. 0200400	DD250E-0202-004	Rubber ring (I)	DD250E橡胶圈 (I)	4
5	1. 29. 10. 0002200	PD350E-1000-022	Nut cap M24	螺母帽 M24	2
6	1. 29. 09. 0001000	PD350E-0900-010	Rear fork shaft nut snap ring	后叉轴螺母卡圈	1
7	1. 29. 09. 0000900	PD350E-0900-009	Rear fork shaft nut M24 × 1.5	后叉轴螺母M24 × 1.5	1
8	PD350E-0200-001	1. 29. 02. 0000100	Spherical blockage Φ25	球面堵塞Φ25	2
9	1. 29. 20. 0000000	PD350E-2000-000	Rear shock absorber	后减震器	1
10	1. 99. 44. 1200000	GB6187-86	Hexagon flange lock nut M12 × 1.25	六角法兰锁紧螺母M12 × 1.25	1
11	1. 71. 99. 2612060	GB5787-85	Hexagon flange bolt M12 × 1.25 × 60	六角法兰面螺栓M12 × 1.25 × 60	1
12	1. 99. 44. 100001R	GB6187-86	Hexagon flange lock nut M10 × 1.5	六角法兰锁紧螺母M10 × 1.5	1
13	1. 99. 26. 1006000	GB5787-86	Hexagon flange bolt M10 × 1.5 × 60	六角法兰面螺栓M10 × 1.5 × 60	1
14	1. 33. 10. 0400000	DD600E-1004-000	Wheel shaft (Φ25 × 360)	轮轴 (Φ25 × 360)	1
15	1. 29. 09. 0001100	PD350E-0900-011	Chain protection pad I	链条保护垫 I	1
16	1. 33. 14. 0100600	DD600E-1401-006	Foot support rubber sleeve	撑脚限位橡胶套	1
17	1. 28. 27. 0000400	DD400R-2700-004	Hexagon pan head screws M6 × 12	内六角盘头螺钉M6 × 12	2
18	1. 01. 14. 0000300	DD250E-1400-003	Single brace spring	单撑拉簧	1
19	1. 33. 14. 0100000	DD600E-1401-000	Single brace	单撑	1
20	1. 99. 61. 1007000	GB882-96	Pin Φ10 × 70	销轴Φ10 × 70	1
21	DD600E-1401-005	1. 33. 14. 0100500	Foot support pin shaft sleeve	撑脚固定销轴轴套	2
22	1. 71. 04. 0700000	DD250G-5F-0407-000	Single support flameout switch	单撑熄火开关	1
23	1. 99. 03. 0601200	GB70-85	Hexagon socket head cap screws M6 × 12	内六角圆柱头螺钉M6 × 12	2
24	1. 29. 02. 0100000	PD350E-0201-000	Chassis	车架主体	1
25	1. 02. 04. 1200000	DD250E-9-0412-000	Horn	喇叭	1
26	1. 99. 27. 060120N	GB5787-86	Hexagon flange bolt M6 × 12	六角法兰面螺栓M6 × 12	1
27	1. 01. 02. 0000500	DD250E-0200-005	Nameplate	DD250E车架铭牌	1
28	1. 99. 64. 0200500	GB827-86	Rivet 2 × 5	铆钉2 × 5	2
29	1. 99. 60. 030250S	GB91-86	Split pin 3 × 25	开口销3 × 25	1
30					

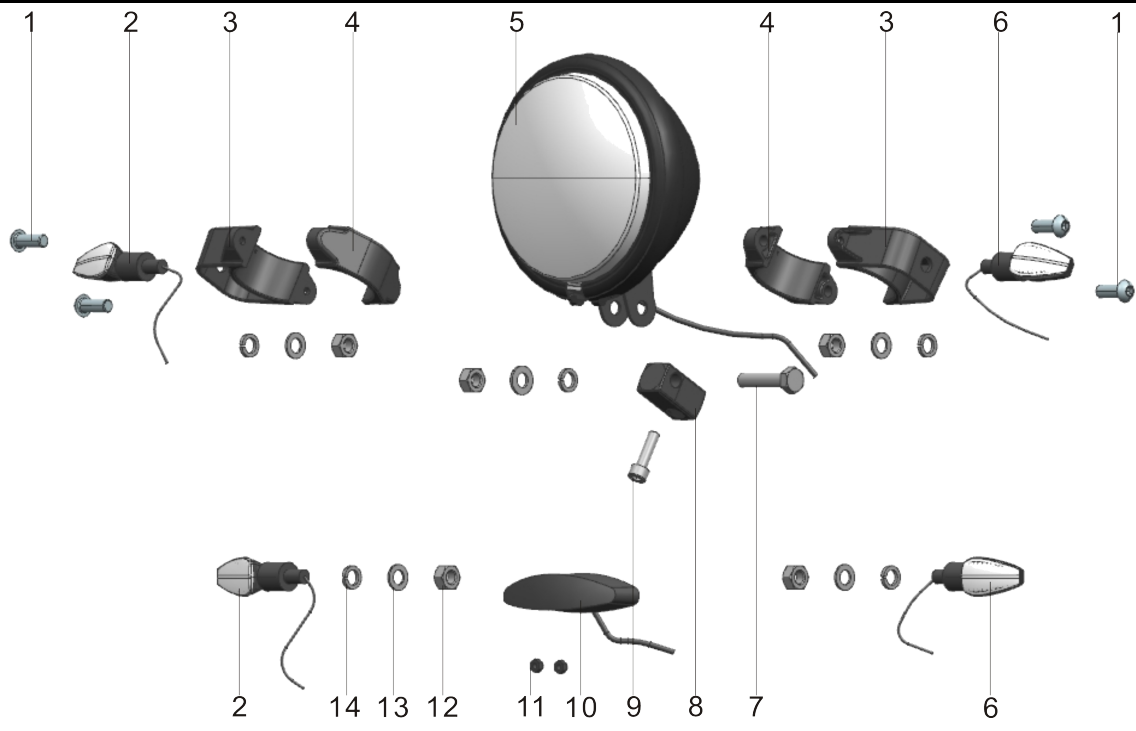

序号	物料编码	零件图号	英文名称	物料名称	用量
NO.	PART CODE	drawing ref.code	Description	Description	Quantity
1	1.99.08.0601200	GB70.2-2000	Hexagon socket flat head screw M6 × 12	内六角平圆头螺钉M6×12	4
2	1.29.03.0300000	PD350E-0303-000	Front right turning light	前右转向灯组件	2
3	1.29.03.0210100	PD350E-0302-101	Front right turning light fixing seat	前转向灯固定座	2
4	PD350E-0302-102	1.29.03.0210200	Front turn signal fixing seat cover	前转向灯固定座盖	2
5	1.C6.03.0100000	DD350E-6C-0301-000	Headlight	前大灯	1
6	1.29.03.0200000	PD350E-0302-000	Front right turning light	前左转向灯组件	2
7	1.99.24.1004500	GB5783-86	Hexagon head bolt M10 × 1.5 × 45	六角头螺栓M10×1.5×45	1
8	1.53.03.0100600	DD300E-6C-0301-006	Headlight holder	大灯座	1
9	1.99.03.100300R	GB70-85	Hexagon socket head cap screws M10 × 1.5 × 30	内六角圆柱头螺钉M10×1.5×30	1
10	1.29.03.0900000	PD350E-0309-000	Taillight assembly	尾灯组件	1
11	1.99.40.0500000	GB/T923	Nut M5	盖形螺母M5	2
12	1.99.42.100000N	GB6170-85	Type 1 hexagon nut M10 × 1.5	1型六角螺母M10×1.5	5
13	1.99.52.1000000	GB97.1-85	Flat washer 10 (Φ10.5 × Φ20 × 2)	平垫圈10 (Φ10.5×Φ20×2)	5
14	1.99.56.100000S	GB93-87	Washer 10	标准型弹性垫圈10	5
15					
16					
17					
18					
19					
20					
21					
22					
23					
24					
25					
26					
27					
28					
29					
30					

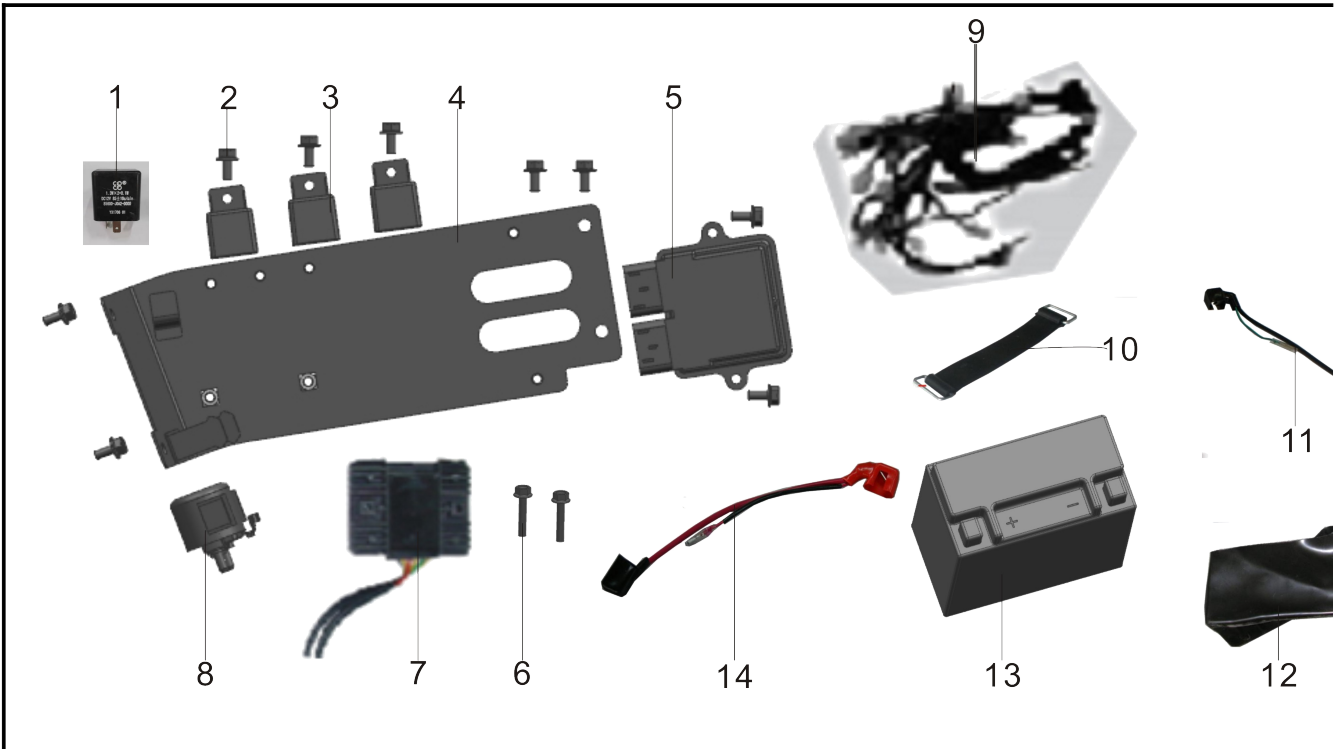

序号	物料编码	零件图号	英文名称	物料名称	用量
NO.	PART CODE	drawing ref.code	Description	Description	Quantity
1	1. 29. 04. 0400000	PD350E-0404-000	flasher	闪光器	1
2	1. 99. 27. 060120N	GB5787-86	Hexagon flange bolt M6 × 12	六角法兰面螺栓M6×12	9
3	1. 56. 32. 0901100	DD250E-9B-3209-011	Relay	继电器	3
4	1. 29. 02. 0400000	PD350E-0204-000	Electrical mounting plate	电器安装板	1
5	1. 23. 32. 0300000	DD250E-9A-3203-000	ECU (DD255MM)	ECU (DD255MM)	1
6	1. 99. 26. 060300R	GB5787-86	Hexagon flange bolt M6 × 30	六角法兰面螺栓M6×30	2
7	2. B7. 0111. 40000	DD269MQ-0111400	Rectifier	调压整流器(防水护套)	1
8	2. 20. 0110. 20000	DD250E-0110200	Starting relay	起动继电器	1
9	1. 29. 04. 0200000	PD350E-0402-000	Main cable assembly	主线缆总成	1
10	1. 01. 04. 0000200	DD250E-0400-002	Buckle (Battery Buckle)	扣带 (电瓶扣带)	1
11	1. 01. 04. 1700000	DD250E-0417-000	Battery negative wiring	蓄电池负极接线	1
12	1. 66. 04. 0400100	DD250G-0404-001	Battery guard	蓄电池护罩	1
13	1. 01. 04. 0300050	DD250E-0403-000	Battery 12V9Ah (without electrolyte)	蓄电池12V9Ah (不带电解液)	1
14	1. 23. 04. 0200000	1. 23. 04. 0200000	Battery positive connection	蓄电池正极接线	1
15					
16					
17					
18					
19					
20					
21					
22					
23					
24					
25					
26					
27					
28					
29					
30					



序号	物料编码	零件图号	英文名称	物料名称	用量
NO.	PART CODE	drawing ref.code	Description	Description	Quantity
1	1. 99. 08. 0605000	GB70. 2-2000	Hexagon socket flat head screw M6×50	内六角平圆头螺钉M6×50	2
2	1. 71. 06. 0000200	DD250G-5F-0600-002	Handle bar balance block	方向把平衡块	2
3	1. 74. 06. 0500010	DD125G-2-0605-000	Right hand grip (double hole)	右手把套 (双孔)	1
4	1. 28. 06. 0410000	DD400R-0604-100	Right switch assembly	小暴龙右开关组件	1
5	1. 29. 06. 0100000	PD350E-0601-000	left handle bar	PD350E左方向把	1
6	1. 99. 03. 060200S	GB70-85	Hexagon socket head cap screws M6×20	内六角圆柱头螺钉M6×20	4
7	1. 29. 06. 0200000	PD350E-0602-000	right handlebar	PD350E右方向把	1
8	1. 28. 06. 0310000	DD400R-0603-100	Left switch assembly	小暴龙左开关组件	1
9	1. 74. 06. 0400000	DD125G-2-0604-000	Left hand grip	左手把套	1
10	1. 57. 06. 0000400	DD250E-6-0600-004	Steering column nut M25×1×17	方向柱螺母 M25×1×17	1
11	1. 57. 06. 0000500	DD250E-6-0600-005	Steering column washer Φ25×Φ38×2	方向柱垫圈 Φ25×Φ38×2	1
12	1. 99. 03. 080300S	GB70-85	Hexagon socket head cap screws M8×30	内六角圆柱头螺钉M8×30	4
13	1. 29. 06. 0300100	PD350E-0603-001	Top tree	PD350E上联板	1
14	1. 99. 03. 120400S	GB70-85	Hexagon socket head cap screws M12×40	内六角圆柱头螺钉M12×40 (不锈钢)	2
15	1. 01. 11. 0000500	DD250E-1100-005	Bushing	衬套	2
16	1. 01. 11. 0000700	DD250E-1100-007	Rubber mat	橡胶垫	2
17	1. 99. 27. 060200N	GB5787-86	Hexagon flange bolt M6×20	六角法兰面螺栓M6×20	2
18	1. 11. 17. 0000500	DD90E-1700-005	Support elastic ring	支承弹性圈	3
19	1. 03. 05. 0101000	DD250E-5D-0501-010	Odometer mounting bracket	里程表安装支架	1
20	1. 99. 04. 060160R	GB823-85	Cross recessed pan head screws M6×16	十字槽盘头螺钉M6×16	3
21	1. 03. 05. 0100000	DD250E-5D-0501-000	Odometer	里程表	1
22	1. 29. 06. 0100200	PD350E-0601-002	handlebar riser	方向把座	2
23	1. 57. 07. 0000100	DD250E-6-0700-001	Bearing nut M25×1×9.5	轴承螺母M25×1×9.5	1
24	1. 45. 06. 1700000	DD350E (3B)-0627-000	Right rearview mirror assembly (E)	右后视镜组件 (E)	1
25	1. 45. 06. 1600000	DD350E (3B)-0626-000	Left rearview mirror assembly (E)	左后视镜组件 (E)	1
26	1. 25. 06. 0500000	DD250E-B-0605-000	Clutch control assembly	离合器操纵总成	1
27	1. 99. 26. 060200R	GB5787-86	Hexagon flange bolt M6×20	六角法兰面螺栓M6×20	2
28	1. 25. 06. 0500500	DD250E-B-0605-005	Back cover	后盖	1
29	1. C4. 06. 0700000	NAC12-0607-000	Clutch control cable	离合器操纵拉索	1
30	1. 03. 06. 0830000	DD250E-5-0608-300	Starting throttle cable	启动油门拉索 (锁紧片式)	1

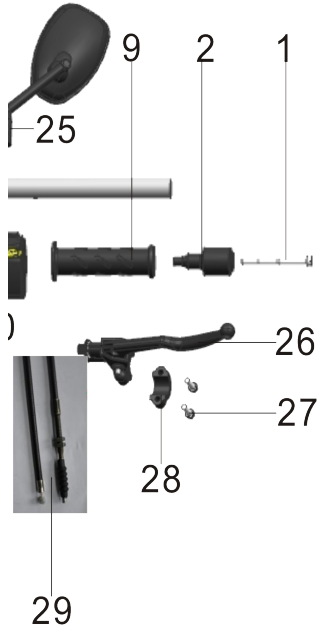

1 riser

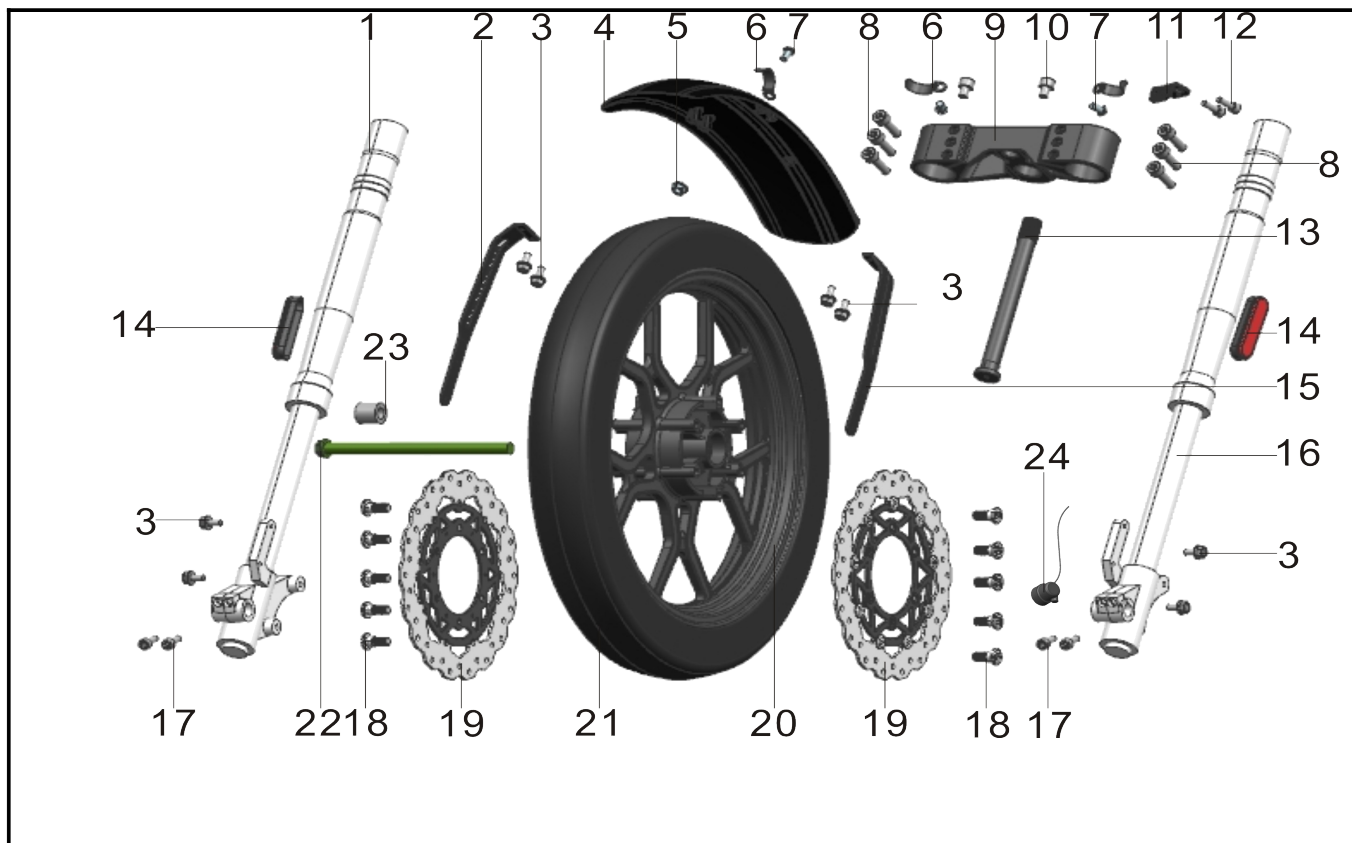

序号	物料编码	零件图号	英文名称	物料名称	用量
NO.	PART CODE	drawing ref.code	Description	Description	Quantity
1	1. C6. 07. 040000A	DD350E-6C-0704-000	Right front shock absorber assembly	DD350E-6C右前减震器组件	1
2	1. 29. 27. 0000300	PD350E-2700-003	Right fender front bracket	PD350E前挡泥板右支架	1
3	1. 99. 27. 060120N	GB5787-86	Hexagon flange bolt M6 × 12	六角法兰面螺栓M6×12	8
4	1. 29. 27. 0000000	PD350E-2700-000	Front wheel cover	前轮罩	1
5	1. 99. 43. 060000N	GB6177-86	Hexagon flange nut M6	六角法兰面螺母M6	1
6	1. 53. 27. 0000100	DD300E-6C-2700-001	Front mudguard clamp	前挡泥板线夹	3
7	1. 99. 08. 0601200	GB70. 2-2000	Hexagon socket flat head screw M6 × 12	内六角平圆头螺钉M6×12	3
8	1. 99. 03. 080300S	GB70-85	Hexagon socket head cap screws M8 × 30	内六角圆柱头螺钉M8×30	6
9	1. 29. 07. 0100100	PD350E-0701-001	Bottom tree	PD350E下联板	1
10	1. 99. 03. 080100R	GB70-85	Hexagon socket head cap screws M8 × 10	内六角圆柱头螺钉M8×10 (镀白锌)	2
11	1. 53. 15. 0200100	DD300E-6C-1502-001	Front lock mount	车头锁安装座	1
12	1. 99. 24. 060160R	GB5783-86	Hexagon head bolt M6 × 16	六角头螺栓M6×16	2
13	1. 57. 07. 0100200	DD250E-6-0701-002	Steering shaft	转向轴	1
14	1. A3. 07. 0500000	DD125E-8-0705-000	Side reflector assembly	DD125E-8侧反光器总成 (E) 欧四	2
15	1. 29. 27. 0000200	PD350E-2700-002	Left fender front bracket	PD350E前挡泥板左支架	1
16	1. C6. 07. 030000A	DD350E-6C-0703-000	Left front shock absorber assembly	DD350E-6C左前减震器组件 (倒置式) 本色	1
17	1. 99. 03. 060200S	GB70-85	Hexagon socket head cap screws M6 × 20	内六角圆柱头螺钉M6×20	4
18	1. 16. 08. 0000300	DD250E-8-0800-003	Hexagon socket head cap screw M8 × 20	内六角螺钉M8×20	12
19	1. 29. 08. 0000200	PD350E-0800-002	Front brake disc Φ300	PD350E前制动盘Φ300	2
20	1. 29. 08. 0100000	PD350E-0801-000	Front aluminum wheel (MT2.5 × 19)	PD350E前铝轮 (MT2.5×19)	1
21	1. B3. 08. 0001200	SPT35-0800-012	Front wheel vacuum tire 100 / 90-19	前轮真空胎100/90-19	1
22	1. C6. 08. 000010N	DD350E-6C-0800-001	Front axle Φ17 × 270	DD350E-6C前轮轴 Φ17×270 (军绿/达克罗)	1
23	1. C6. 08. 0000400	DD350E-6C-0800-004	Front wheel right outer sleeve	DD350E-6C前轮右外轴套	1
24	1. C6. 05. 0000100	DD350E-6C-0500-001	LCD odometer speed sensor	液晶里程表速度传感器	1

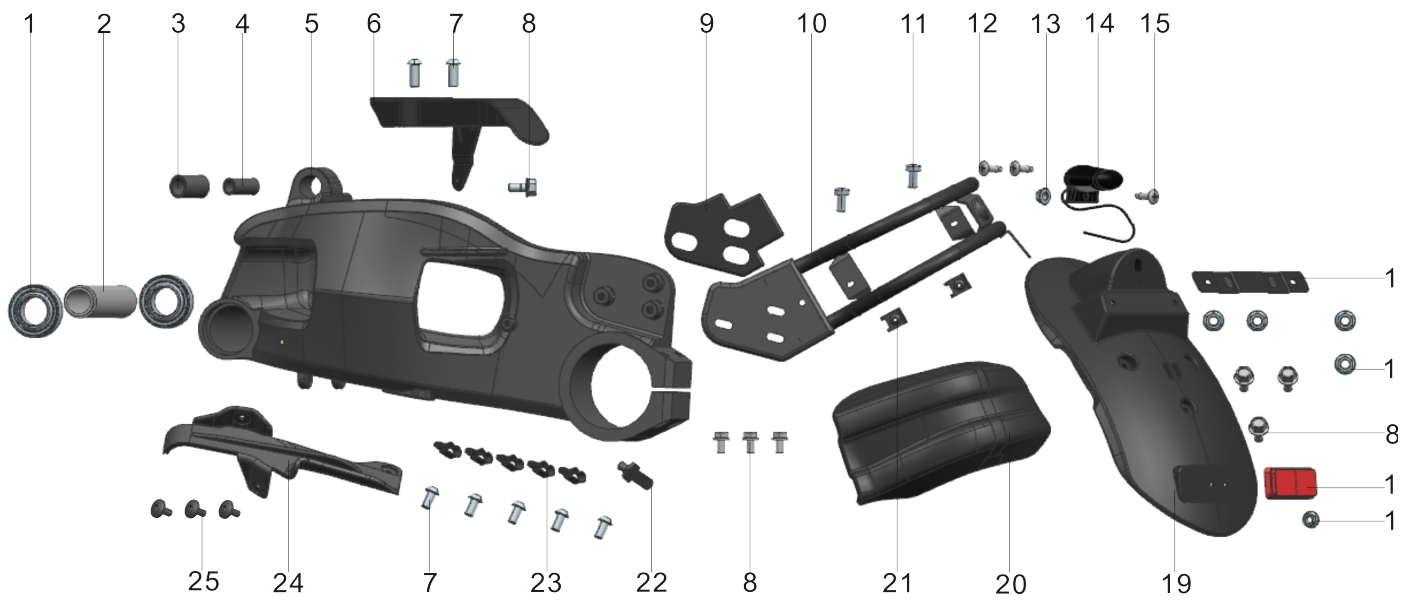

序号	物料编码	零件图号	英文名称	物料名称	用量
NO	PART CODE	drawing ref.code	Description	Description	Quantity
1	1. 99. 72. 6006000	GB278-88	Bearing 6006ZZ-NSK	轴承6006ZZ-NSK	2
2	1. 29. 09. 0000500	PD350E-0900-005	Rear fork shaft sleeve	后叉轴轴套	1
3	1. 33. 14. 0200100	DD600E-1402-001	Main pedal mounting rod nylon sleeve	主脚踏安装杆尼龙套	1
4	1. 71. 20. 0100200	DD250E-5F-2001-002	Shaft sleeve ($\Phi 12.5 \times \Phi 17.5 \times 35$)	轴套 ($\Phi 12.5 \times \Phi 17.5 \times 35$)	1
5	1. 29. 09. 0100000	PD350E-0901-000	Rear fork	后摇架	1
6	1. 29. 09. 0300100	PD350E-0903-001	Chain cover	链条罩	1
7	1. 99. 08. 0601200	GB70. 2-2000	Hexagon socket flat head screw M6 \times 12	内六角平圆头螺钉M6 \times 12	7
8	1. 99. 27. 060120N	GB5787-86	Hexagon flange bolt M6 \times 12	六角法兰面螺栓M6 \times 12	4
9	1. 29. 21. 0110500	PD350E-2101-105	Buffer block	缓冲块	1
10	1. 29. 21. 0110000	PD350E-2101-100	Rear mudguard	后挡泥板架	1
11	1. 99. 15. 4801600	GB845-85	Cross pan head tapping screws ST4.8 \times 16	十字盘头自攻螺钉ST4.8 \times 16	2
12	1. 99. 15. 3500900	GB845-85	Cross pan head tapping screws ST3.5 \times 9	十字盘头自攻螺钉ST3.5 \times 9	2
13	1. 99. 44. 050000N	GB6187-86	Hexagon flange nut M5	六角法兰螺母M5	2
14	1. 29. 03. 1000000	PD350E-0310-000	License plate light assembly	牌照灯组件	1
15	1. 99. 05. 050120N	GB819-85	Cross recessed countersunk head screws M5 \times 12	十字槽沉头螺钉M5 \times 12	1
16	1. 01. 03. 1000100	DD250E-0310-001	License plate installation plate	牌照安装板	1
17	1. 99. 43. 060000N	GB6177-86	Hexagon flange nut M6	六角法兰面螺母M6	4
18	1. 45. 21. 0100000	DD350E-3B-2100-000	Rear reflector assembly (E)	后反光器组件 (E)	1
19	1. 29. 21. 0100100	PD350E-2101-001	Rear mudguard	后挡泥板	1
20	1. 29. 21. 0100200	PD350E-2101-002	Rear fender frame cover	PD350E后挡泥板架盖板	1
21	1. D5. 16. 0500300	DD150E-3-1603-003	Locking piece	锁紧片	2
22	1. 29. 09. 0100100	PD350E-0901-001	Limit pin	限位销轴	1
23	1. 29. 09. 0001000	PD350E-0900-010	Rear cradle cable clamp	后摇架线夹	5
24	1. 29. 09. 0001100	PD350E-0900-011	Chain protection pad (II)	链条保护垫 (II)	1
25	1. 28. 27. 0000400	DD400R-2700-004	Hexagon pan head screws M6 \times 12	内六角盘头螺钉M6 \times 12	3

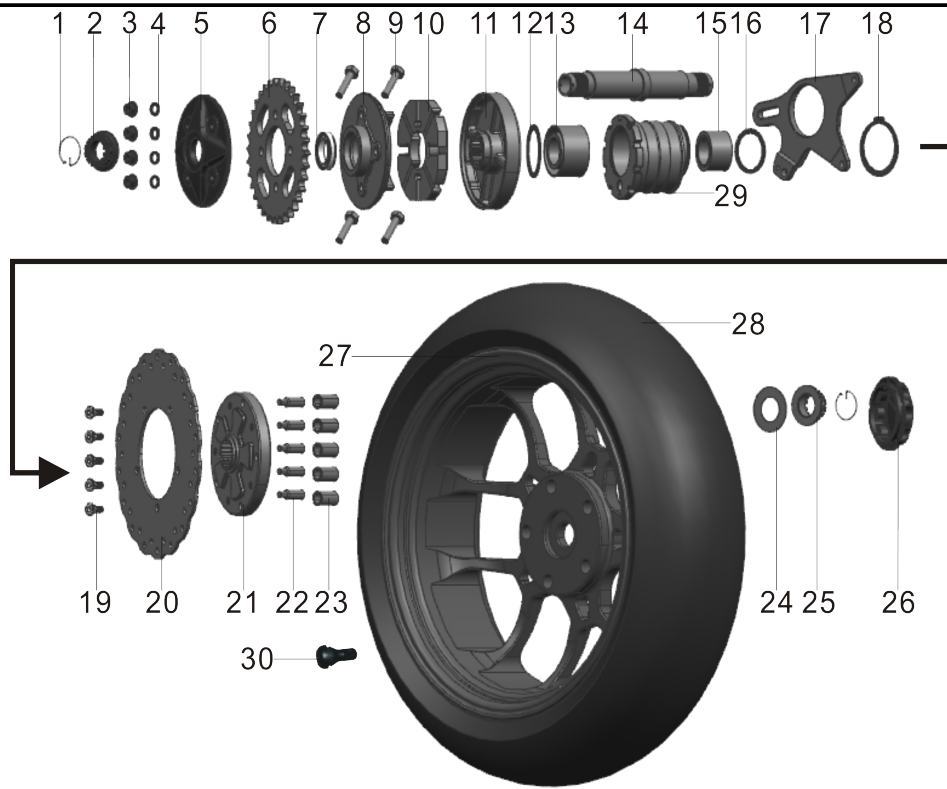

序号	物料编码	零件图号	英文名称	物料名称	用量
NO.	PART CODE	drawing ref.code	Description	Description	Quantity
1	1.29.10.0002200	PD350E-1000-022	Rear axle nut snap ring	后轮轴螺母卡圈	2
2	1.29.10.0002100	PD350E-1000-021	Left nut of rear axle M30 × 1.5	后轮轴左螺母M30×1.5	1
3	1.99.44.100001R	GB6187-86	Hexagon flange nut M10 × 1.5	六角法兰螺母M10×1.5	4
4	1.99.56.100000S	GB93-87	Washer 10	标准型弹性垫圈10	4
5	1.29.10.0000300	PD350E-1000-003	Driven sprocket pressure plate	从动链轮压板	1
6	1.C5.10.0000800	DD125E-3C-1000-008	Driven sprocket	从动链轮	1
7	1.99.72.6906000	GB279-88	Bearing 6906Z	轴承6906Z	1
8	1.29.10.0000500	PD350E-1000-005	Buffer body assembly	缓冲体组件	1
9	1.99.26.1004700	GB5787-86	Hexagon flange bolt M10 × 1.5 × 47	六角法兰面螺栓M10×1.5×47	4
10	1.29.10.0000600	PD350E-1000-006	Buffer block	缓冲块	1
11	1.29.10.0000700	PD350E-1000-007	Buffer block seat	缓冲块座	1
12	1.99.65.6300000	GB893.1-86	Circlip 63	孔用弹性挡圈63	1
13	1.29.10.0002000	PD350E-1000-020	Rear wheel bearing DAC35640067	后轮轴承 DAC35640067	1
14	1.29.10.0000100	PD350E-1000-001	Rear axle	后轮轴	1
15	1.99.71.0035500	GB/T5801-94	Bearings NKI35 / 30-NTN	单列滚针轴承 NKI35/30-NTN	1
16	1.99.65.5200000	GB893.1-86	Retaining ring 52	孔用弹性挡圈52	1
17	1.29.10.0300100	PD350E-1003-001	Rear brake pump fixing plate	后制动泵固定板	1
18	1.99.63.6500000	GB894.1-86	Snap ring for shaft 65	轴用弹性挡圈65	1
19	1.16.08.0000300	DD250E-8-0800-003	Hexagon socket head cap screw M8 × 20	内六角螺钉M8×20	5
20	1.29.10.0001700	PD350E-1000-017	Rear brake discΦ260	后制动盘Φ260	1
21	1.29.10.0000900	PD350E-1000-009	Rear wheel seat	后轮座	1
22	1.29.10.0001100	PD350E-1000-011	Rear wheel alignment pin	后轮定位销	5
23	1.29.10.0001200	PD350E-1000-012	Rear wheel alignment pin bushing	后轮定位销衬套	5
24	1.29.10.0002300	PD350E-1000-023	Rear axle gasket	后轮轴垫片	1
25	1.29.10.0001900	PD350E-1000-019	Right nut of rear axle M30 × 1.5	后轮轴右螺母M30×1.5	1
26	1.29.10.0001000	PD350E-1000-010	Rear wheel axle nut decorative cover	后轮轴螺母装饰盖	1
27	1.29.10.0100000	PD350E-1001-000	Rear aluminum wheel assembly	后铝轮组件	1
28	1.29.10.0001600	PD350E-1000-016	Rear tires	后轮真空胎	1
29	1.29.10.0000800	PD350E-1000-008	Eccentric bushing	偏心轴套	1
30	1.01.10.0000500	DD250E-1000-005	Valve	气门嘴	1

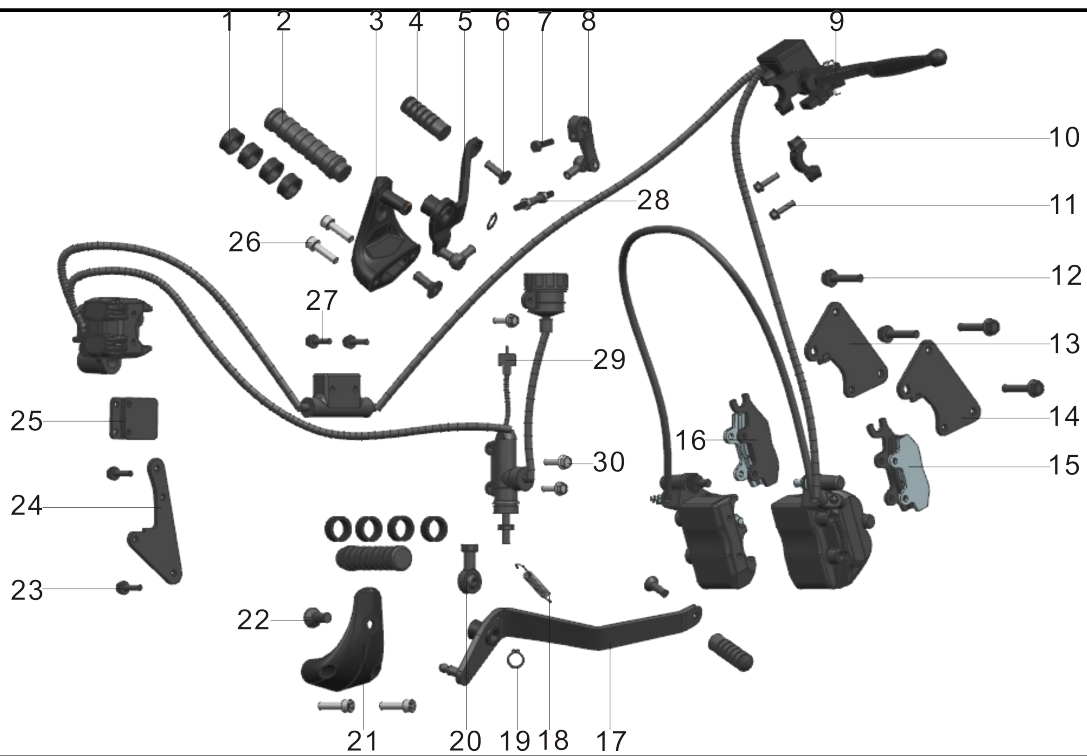

序号	物料编码	零件图号	英文名称	物料名称	用量
NO.	PART CODE	drawing ref.code	Description	Description	Quantity
1	1. 57. 14. 0240300	DD250E-6-1402-403	Rubber sleeve (4) $\Phi 27 \times \Phi 21 \times 11$	橡胶套(四) $\Phi 27 \times \Phi 21 \times 11$	8
2	1. 29. 14. 0600300	PD350E-1406-003	Main pedal	主脚踏	2
3	1. 29. 14. 0500100	PD350E-1405-001	Left main pedal mount	左主脚踏安装座(铝)	1
4	1. 33. 14. 0600500	DD600E-1406-005	Treadle	踏杆	2
5	1. 29. 14. 0610000	PD350E-1406-100	Gear shift assembly	变速杆组件	1
6	1. 99. 02. 0802500	GB70. 3-2000	Hexagon socket countersunk head screws M8 \times 25	内六角沉头螺钉M8 \times 25	2
7	1. 99. 24. 050200R	GB5783-86	Hexagon head bolt M5 \times 20	六角头螺栓M5 \times 20	1
8	1. 17. 14. 0800000	DD150E-2-1401-000	Rocker arm assembly	摇臂组件	1
9	1. 29. 10. 0200000	PD350E-1002-000	Brake pump assembly (CBS)	制动泵总成(CBS)	1
10	1. 29. 10. 0200100	PD350E-1002-001	Back cover	后盖	1
11	1. 99. 26. 060200R	GB5787-86	Hexagon flange bolt M6 \times 20	六角法兰面螺栓M6 \times 20	2
12	1. 99. 27. 0804000	GB5789-86	Hexagon flange bolt M8 \times 40	六角法兰面螺栓M8 \times 40	4
13	1. 29. 10. 0210100	PD350E-1002-101	Left front brake pump connection plate	左前制动泵连接板	1
14	1. 29. 10. 0210300	PD350E-1002-103	Right front brake pump connection plate	右前制动泵连接板	1
15	1. 29. 10. 0210400	PD350E-1002-104	Right front brake pump brake pads	右前制动泵刹车片	1
16	1. 29. 10. 0210200	PD350E-1002-102	Left front brake pump brake pads	左前制动泵刹车片	1
17	1. 29. 14. 0710000	PD350E-1407-100	Rear brake connecting rod assembly	后制动连杆组件	1
18	1. 68. 14. 0300300	DD300G-1403-003	Return spring	回位弹簧	1
19	1. 99. 63. 1400000	GB894. 1-86	Circlip for shaft 14	轴用弹性挡圈14	2
20	1. 99. 73. 1500000	GB9163-91	Bearing GE15ES	关节轴承GE15ES	1
21	1. 29. 14. 0600100	PD350E-1406-001	Right main pedal mount	右主脚踏安装座(铝)	1
22	1. 99. 02. 1002500	GB70. 3-2000	Hexagon socket countersunk head screws M10 \times 25	内六角沉头螺钉M10 \times 25	2
23	1. 99. 27. 080160R	GB5789-86	Hexagon flange bolt M8 \times 16	六角法兰面螺栓M8 \times 16	2
24	1. 29. 10. 0210500	PD350E-1002-105	Rear brake pump connection plate	后制动泵连接板	1
25	1. 29. 10. 0210600	PD350E-1002-106	Rear brake pump brake pads	后制动泵刹车片	1
26	1. 99. 03. 080300S	GB70-85	Hexagon socket head cap screws M8 \times 30	内六角圆柱头螺钉M8 \times 30	4
27	1. 99. 26. 0604500	GB5787-86	Hexagon flange bolt M6 \times 45	六角法兰面螺栓M6 \times 45	2
28	1. 30. 14. 0600700	DD350E-2-1406-007	Double head screw-60mm	双头螺杆-60mm	1
29	1. 29. 10. 0210700	PD350E-1002-107	Switch assembly	开关总成	1
30	1. 99. 26. 0601200	GB5787-86	Hexagon flange bolt M6 \times 12	六角法兰面螺栓M6 \times 12	3

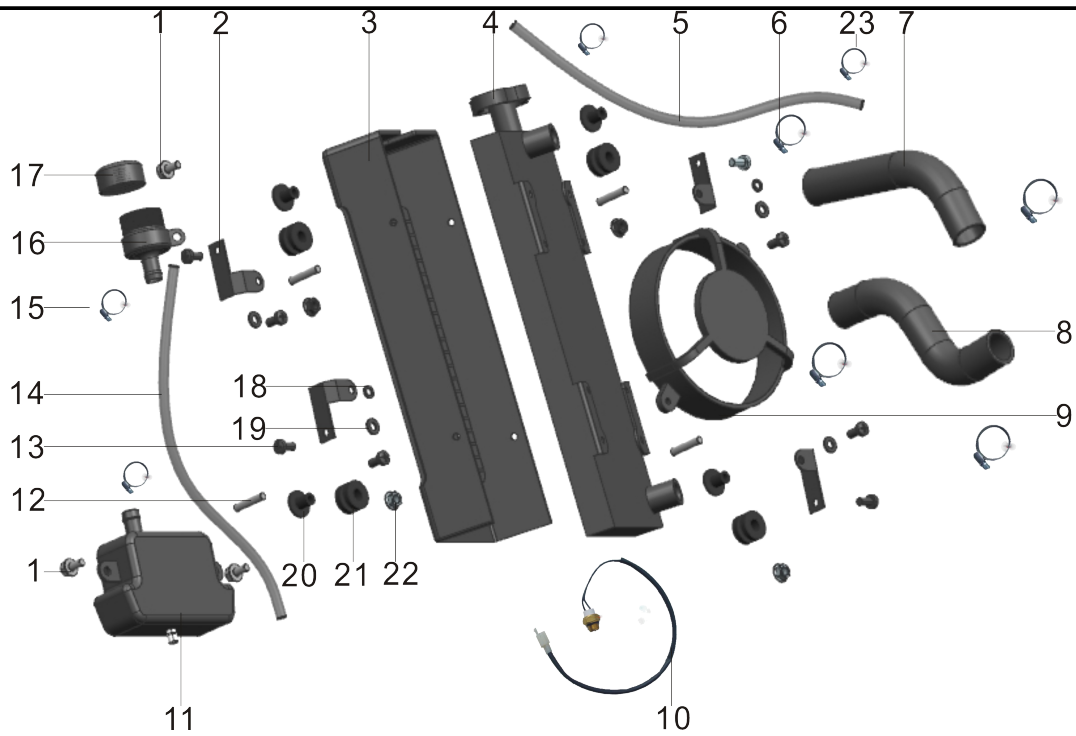

序号	物料编码	零件图号	英文名称	物料名称	用量
NO.	PART CODE	drawing ref.code	Description	Description	Quantity
1	1. 99. 27. 060120N	GB5787-86	Hexagon flange bolt M6 × 12	六角法兰面螺栓M6×12	3
2	1. 68. 00. 0000300	DD300G-0000-003	Radiator cover bracket (left)	水箱罩支架 (左)	2
3	1. 63. 00. 0000400	DD300E-6-0000-004	Radiator cover	水箱罩	1
4	2. 27. 0117. 11040	DD300G-0117110D	Radiator L = 333	水箱 (加长) L=333	1
5	2. 24. 0117. 00500	DD250E-9A-0117005	Auxiliary radiator inlet pipe	辅助水箱进水管	1
6	2. 23. 0117. 01000	DD250E-9-0117010	Pipe clamp (φ27)	DD250E-9管夹 (φ27)	4
7	1. 63. 00. 0100100	DD300E-6-0001-001	Radiator inlet pipe-elbow	DD300E-6水箱进水管-弯管	1
8	2. 23. 0117. 00210	DD253MM-0117002A	Box outlet pipe φ17.5 (shaped pipe)	箱出水管 φ17.5 (异形管)	1
9	2. 24. 0117. 20030	DD250E-9A-0117200B	Fan assembly	风扇组件 (松下)	1
10	2. 23. 0117. 12010	DD250E-9-0117120	Fan switch	风扇开关	1
11	1. 72. 00. 0000110	DD250G-2N-0000-001	Kettle	水壶 (大水箱)	1
12	1. 72. 00. 0000400	DD250G-2N-0000-001	Double-head screw M6 × 32	双头螺杆M6×32 (水箱)	1
13	1. 99. 04. 050120S	GB818-85	Cross recessed pan head screws M5 × 12	十字槽盘头螺钉M5×12	8
14	1. 57. 00. 0000510	DD250E-6-0000-005	Kettle connecting pipe Φ11 × Φ15 (straight pipe)	水壶连接管 Φ11×Φ15 (直管)	1
15	2. 23. 0117. 00300	DD250E-9-0117003	D water pipe clamp φ11	D水管夹 φ11	2
16	1. 57. 07. 0000400	DD250E-6-0700-004	Lower Cover	下盖	1
17	1. 57. 07. 0000200	DD250E-6-0700-002	Upper Cover	上盖	1
18	1. 99. 56. 050000H	GB93-87	Spring pad 5	弹垫5	2
19	1. 99. 54. 0500000	GB95-85	Flat pad 5	平垫5	4
20	2. 24. 0117. 00700	DD250E-9A-0117007	Radiator Damping Washer	水箱减震垫	4
21	2. 24. 0117. 00800	DD250E-9A-0117008	Radiator rubber	水箱橡胶垫	4
22	1. 99. 44. 060000N	GB6187-86	All metal hexagonal flange lock nut M6	全金属六角法兰锁紧螺母M6 (军绿/达克罗)	
23	2. 23. 0117. 00300	DD250E-9-0117003	Water pipe clamp φ11	水管夹 φ11	2
24					
25					
26					
27					
28					
29					
30					

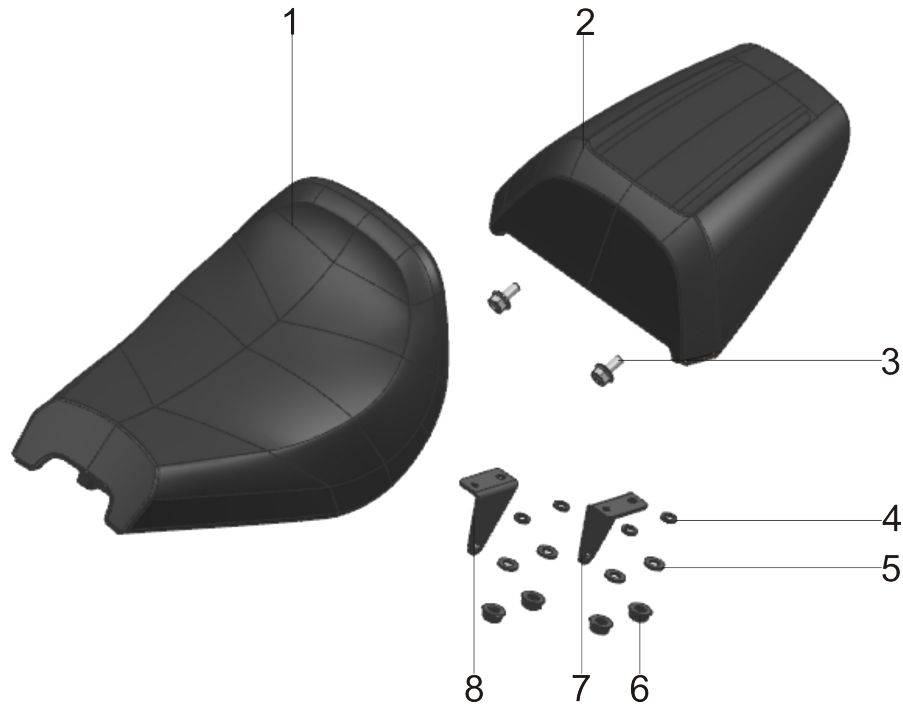

序号	物料编码	零件图号	英文名称	物料名称
NO.	PART CODE	drawing ref.code	Description	Description
1	1. 29. 13. 0100000	PD350E-1301-000	Main seat	PD350E主座垫
2	1. 29. 13. 0200000	PD350E-1302-000	Vice seat	PD350E副座垫
3	1. 99. 27. 060160R	GB5789-86	Hexagon flange bolt M6 × 16 (white zinc plated S = 13)	六角法兰面螺栓M6×16 (镀锌 S=13)
4	1. 99. 56. 060000S	GB93-87	Standard elastic washer 6 (stainless steel)	标准型弹性垫圈6 (不锈钢)
5	1. 99. 52. 060000S	GB97. 1-85	Flat washer 6 (Φ6.4 × Φ12 × 1.5) stainless steel	平垫圈6 (Φ6.4×Φ12×1.5) 不锈钢
6	1. 99. 43. 060000N	GB6177-86	Hexagon flange nut M6 (stainless steel)	六角法兰面螺母M6 (不锈钢)
7	1. 29. 13. 0100100	PD350E-1301-001	PD350E main seat cushion left mounting plate	PD350E主座垫左安装板
8	1. 29. 13. 0100200	PD350E-1301-002	PD350E main seat cushion right mounting plate	PD350E主座垫右安装板
9				
10				
11				
12				
13				
14				
15				
16				
17				
18				
19				
20				
21				
22				
23				
24				
25				
26				
27				
28				
29				
30				

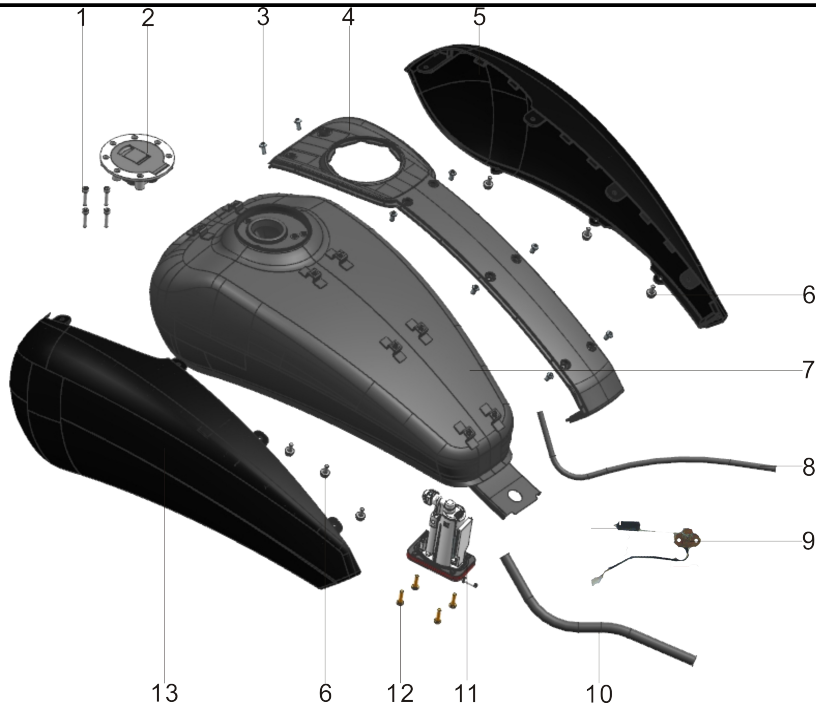

序号	物料编码	零件图号	英文名称	物料名称	用量
NO.	PART CODE	drawing ref.code	Description	Description	Quantity
1	1. 99. 03. 050220	GB70-85	Hexagon socket head cap screws M5 × 22	内六角圆柱头螺钉M5×22	4
2	1. 53. 13. 000000	DD300E-6C-1500-000	Fuel tank lock and head lock assembly	油箱锁及车头锁总成	1
3	1. 99. 08. 060160	GB70. 2-2000	Hexagon socket flat head screw M6 × 16	内六角平圆头螺钉M6×16	8
4	1. 29. 11. 000030	PD350E-1100-003	Fuel tank decorative cover	油箱中装饰罩	1
5	1. 29. 11. 000040	PD350E-1100-004	Fuel tank left decorative cover	油箱右装饰罩	1
6	1. 99. 27. 060120	GB5787-86	Hexagon flange bolt M6 × 12	六角法兰面螺栓M6×12	8
7	1. 29. 11. 000010	PD350E-1100-001	Fuel tank	油箱主体	1
8	1. 03. 11. 000030	DD250E-5-1100-003	Oil delivery hoseΦ4.5 × Φ8.5	输油胶管Φ4.5×Φ8.5	1, 03
9	1. 28. 03. 040000	DD400R-0504-000	oil sensor	DD400R油重传感器(防水护套)	1
10	1. 03. 32. 090030	DD250E-5F-3209-003	High pressure tubing Φ8 × Φ15	高压油管Φ8×Φ15	0, 69
11	1. 28. 32. 090000	DD400R-3209-000	Oil pump assembly (four holes) JH-A820B	油泵总成(四孔) JH-A820B	1
12	1. 99. 04. 050200	GB818-85	Cross recessed pan head screws M5 × 20	十字槽盘头螺钉M5×20	4
13	1. 29. 11. 000020	PD350E-1100-002	Fuel tank left decorative cover	油箱左装饰罩	1
14					
15					
16					
17					
18					
19					
20					
21					
22					
23					
24					
25					
26					
27					
28					
29					
30					

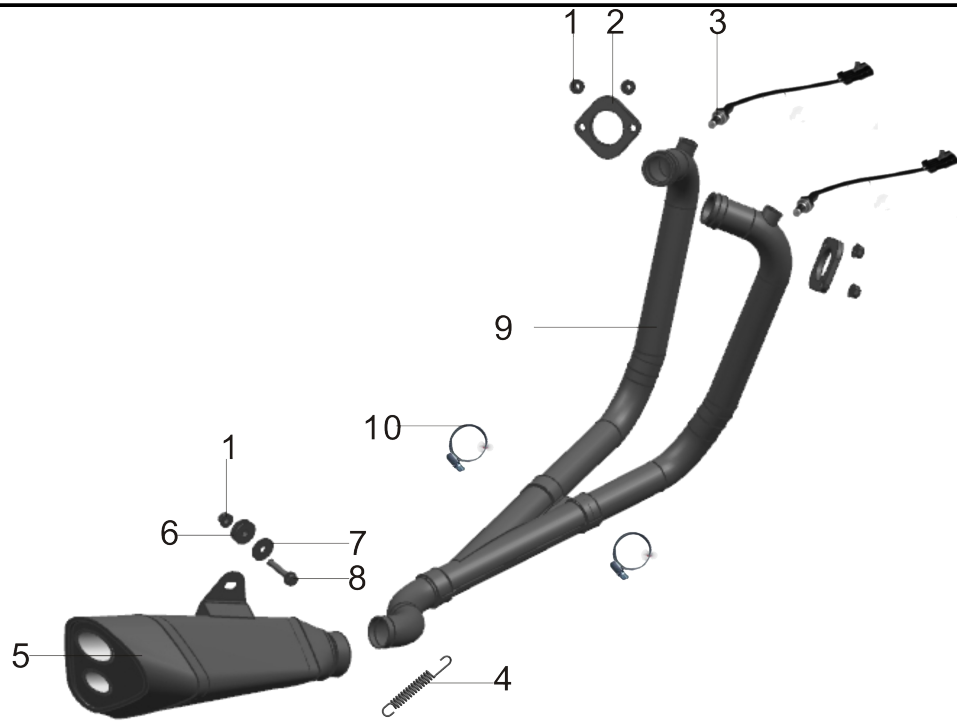

序号	物料编码	零件图号	英文名称	物料名称	用量
NO.	PART CODE	drawing ref.code	Description	Description	Quantity
1	1. 99. 44. 080000R	GB6187-86	All metal hexagon flange lock nut M8	全金属六角法兰锁紧螺母M8	4
2	1. 01. 18. 0000210	DD250E-1800-002	Exhaust pipe gasket (iron)	排气管密封垫(铁)	2
3	1. A3. 32. 0600000	DD125E-8-3206-000	Oxygen sensor (M12 × 1.25)	氧传感器 (M12×1.25)	2
4	1. 29. 18. 0200100	PD350E-1802-001	Spring	弹簧	1
5	1. 29. 18. 0200000	PD350E-1802-000	Muffler assembly	消声器组件	1
6	1. 11. 11. 0000500	DD90E-1100-005	Rubber band	橡胶圈	1
7	1. 11. 11. 0000700	GB5287-2002	Washer $\phi 9 \times \phi 28 \times 2$	垫圈 $\phi 9 \times \phi 28 \times 2$	1
8	1. 99. 27. 0804000	GB5789-86	Hexagon flange bolt M8 × 40	六角法兰面螺栓M8×40	1
9	1. 29. 18. 0100000	PD350E-1801-000	Exhaust pipe assembly	排气管组件	1
10	1. 01. 17. 0000300	DD250E-1700-003	Clamp ($\phi 50$)	卡箍($\phi 50$)	2
11					
12					
13					
14					
15					
16					
17					
18					
19					
20					
21					
22					
23					
24					
25					
26					
27					
28					
29					
30					

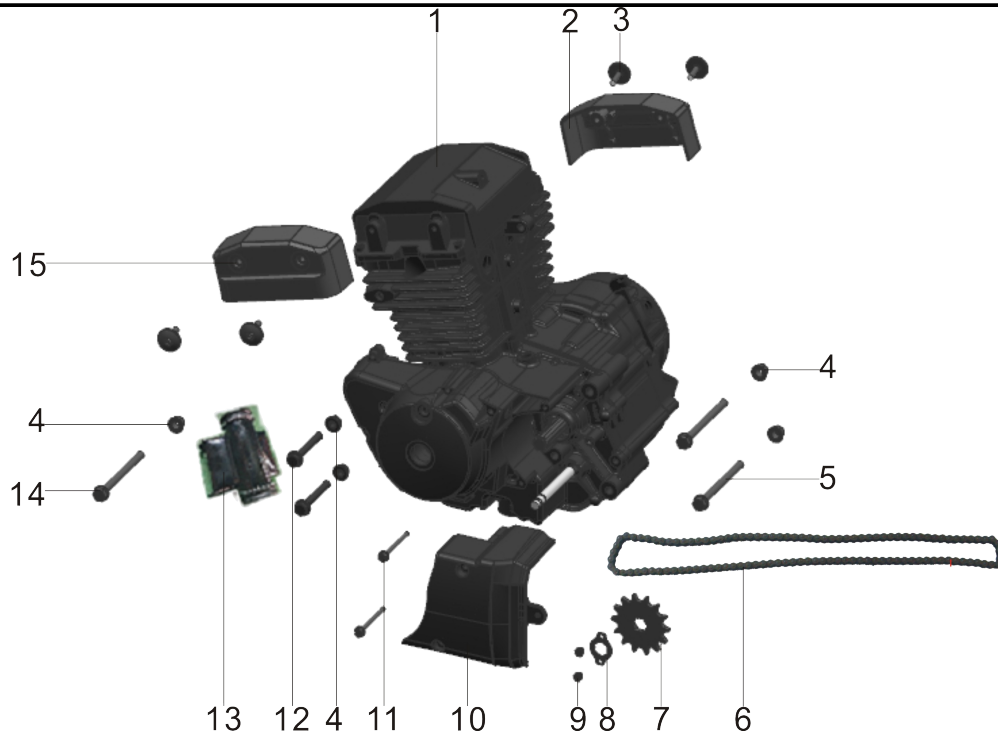

序号	物料编码	零件图号	英文名称	物料名称	用量
NO.	PART CODE	drawing ref.code	Description	Description	Quantity
1	2.00.17.0000100	DD400R	DD269MQ water-cooled engine	DD269MQ水冷发动机	1
2	2.27.0101.02708	DD300E-6-0101027	Right side cover of cylinder head cover (matte black)	汽缸盖罩右侧盖(亚光黑)	2
3	2.20.0101.0040N	DD250E-0101004B	Connecting screw for cylinder head cover	汽缸盖罩连接螺钉	4
4	1.99.44.100001R	GB6187-86	Hexagon flange lock nut M10 × 1.5	六角法兰锁紧螺母M10×1.5	5
5	1.99.26.1011200	GB5787-86	Hexagon flange bolt M10 × 1.5 × 112	六角法兰面螺栓M10×1.5×112	2
6	1.99.79.7112800		Chain 530OU-1 × 128L	链条530OU-1×128L	1
7	2.20.0114.40110	DD250E-0114401B	Countershaft sprocket (14T, 530)	副轴链轮(14T, 530)	1
8	2.20.0114.40200	DD250E-0114402A	Countershaft sprocket fixing plate	副轴链轮固定板	1
9	2.99.24.060100R	GB5783-86	Hexagon head bolt M6 × 10	六角头螺栓 M6×10	2
10	1.29.01.1311000	PD350E-0113-110	Rear cover of left crankcase	左曲轴箱后盖	1
11	2.20.0108.0060S	DD250E-0108006A	Bolt M6 × 65	螺栓 M6×65	2
12	9.99.26.1007000	GB5787-86	Hexagon flange bolt M10 × 1.5 × 70	六角法兰面螺栓M10×1.5×70	2
13	1.57.02.0500000	DD250E-6-0205-000	Lower engine fixing frame	发动机下固定架	1
14	1.99.26.1013200	GB5787-86	Hexagon flange bolt M10 × 1.5 × 132	六角法兰面螺栓M10×1.5×132	1
15	2.27.0101.02308	DD300E-6-0101023	Left side cover of cylinder head cover (matte black)	汽缸盖罩左侧盖(亚光黑)	1
16					
17					
18					
19					
20					
21					
22					
23					
24					
25					
26					
27					
28					
29					
30					

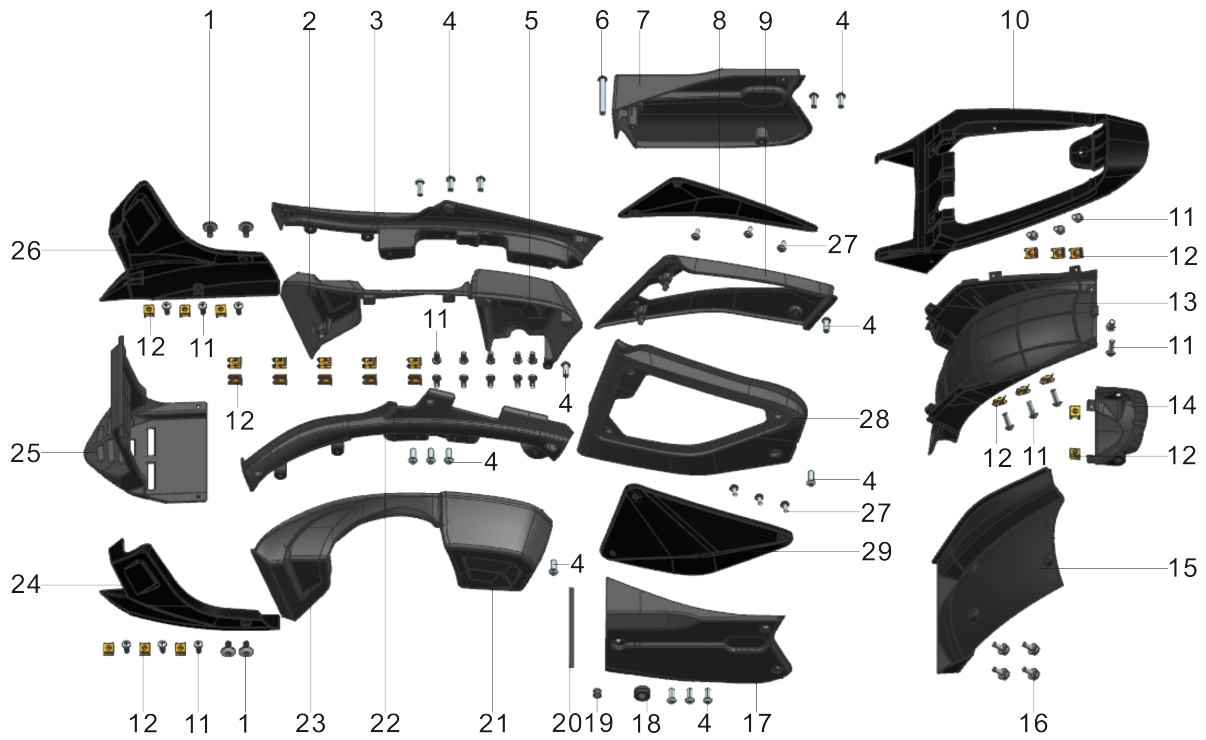

序号	物料编码	零件图号	英文名称	物料名称	用量
NO.	PART CODE	drawing ref.code	Description	Description	Quantity
1	1.28.27.0000400	DD400R-2700-004	Hexagon pan head screws M6 × 12	内六角盘头螺钉M6×12	4
2	1.29.16.040020C	PD350E-1604-002	Right front cover	右前护罩	1
3	1.29.02.0010200	PD350E-0200-102	Right decorative strip	右筋板装饰条	1
4	1.99.08.0601600	GB70.2-2000	Hexagon socket flat head screw M6 × 16	内六角平圆头螺钉M6×16	13
5	1.29.16.030020C	PD350E-1603-002	Throttle body right decorative cover	节气门体右装饰罩	1
6	1.99.08.0605000	GB70.2-2000	Hexagon socket flat head screw M6 × 50	内六角平圆头螺钉M6×50	1
7	1.29.15.040010C	PD350E-1504-001	Right rear cover	右后盖	1
8	1.29.16.020020C	PD350E-1602-002	Rightside cover plate	右内护板	1
9	1.29.16.020010C	PD350E-1602-001	Right side cover	右护板	1
10	1.29.15.010010C	PD350E-1501-001	Rear tail cover	后尾罩	1
11	1.99.17.4201300	GB2670.1-2004	Hexagon socket pan head tapping screws ST4.2 × 13	内六角盘头自攻螺钉ST4.2×13	24
12	1.D5.16.0500300	DD150G-3-1605-003	Locking piece	锁紧片	24
13	1.29.21.0000100	PD350E-2100-001	Rear wheel cover (upper)	后轮罩(上)	1
14	1.29.15.030010C	PD350E-1503-001	Taillight cover	尾灯罩	1
15	1.29.21.0000200	PD350E-2100-002	Tear wheel cover (lower)	后轮罩(下)	1
16	1.99.26.0601600	GB5787-86	Hexagon flange bolt M6 × 16	六角法兰面螺栓M6×16	4
17	1.29.15.040020C	PD350E-1504-002	Left cover	左盖	1
18	1.11.17.0000500	DD90E-1700-005	Support elastic ring	支承弹性圈	1
19	1.11.17.0000600	DD90E-1700-006	Support inner casing (Φ7 × Φ9 × 7)	支承内套管(Φ7×Φ9×7)	1
20			Sponge strip	海绵条	
21	1.29.16.030010C	PD350E-1603-001	throttle body left decorative cover	节气门体左装饰罩	1
22	1.29.02.0010100	PD350E-0200-101	left decorative strip	左筋板装饰条	1
23	1.29.16.040010C	PD350E-1604-001	left front cover	左前护罩	1
24	1.29.00.000020C	PD350E-0000-002	kettle cover left	水壶罩左体	1
25	1.29.00.0000100	PD350E-0000-001	kettle cover	水壶罩	1
26	1.29.00.000030C	PD350E-0000-003	kettle cover right	水壶罩右体	1
27	1.99.15.3500900	GB845-85	screws ST3.5 × 9	十字槽盘头自攻螺钉ST3.5×9	6
28	1.29.16.010010C	PD350E-1601-001	left side cover	左护板	1
29	1.29.16.010020C	PD350E-1601-002	left inside cove	左内护板	1
30					

